

# QFP-Socket Cover Series Q2101

# QFP-Base Socket Series Q2001

### Content of delivery Series Q2101

QFP-Socket cover and 4 screws M2x6

### Content of delivery Series Q2001

QFP-Base socket and a cross slot screwdriver for M2

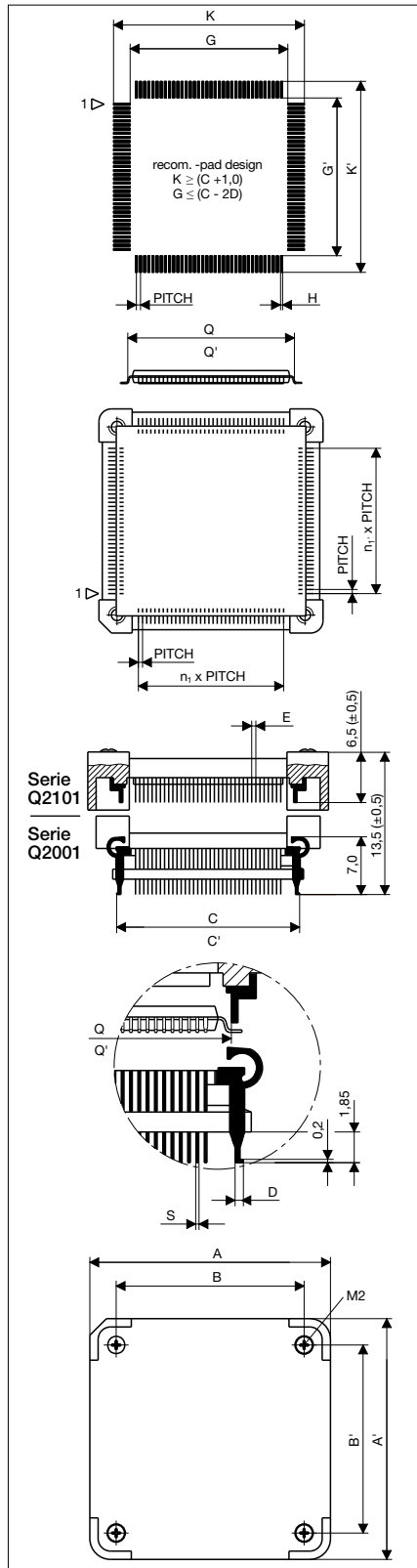

### Contact

Beryllium copper, nickel 1-3 µm,  
Q2101 = gold 0.5 µm, Q2001 = gold 0.25 µm

### Insulator body

Liquid cristall polymer (LCP) self-extinguishing  
rated UL94V0

**Operation temperature** -25 up to +85°C

### Resistance to solder heat

Reflow 260°C, 10 sec.  
Manual 350°C, 5 sec./  
per contact

**Mechanical life** >100 cycles

**Rated voltage** 100 V<sub>RMS</sub>/150 VDC

**Contact resistance** < 70 mΩ

**Insulation resistance** > 5 x 10<sup>8</sup> Ω

**Current carrying capacity** per contact 0,5 A

**Moisture sensibility level (MSL)**

J-STD-020C Level 2

**RoHS-conform**

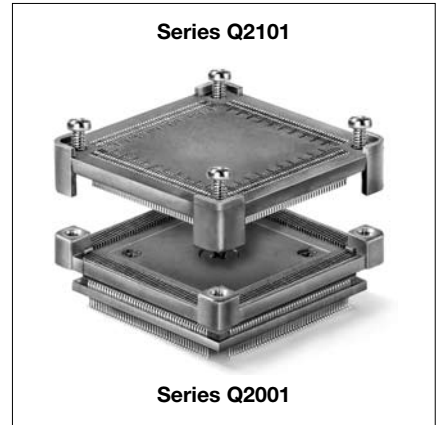

A	B	C	D	E	H	Q'	S	n <sub>1</sub>	Pitch	Pins	S=Square R=Rectangular	Part No.	
												Q2001	Q2101
19.00	12.65	12.1	0.5	0.18	0.2	11.22	0.18	19	0.4	80	S	3303231	3303275
21.00	14.65	14.1	0.5	0.18	0.2	13.20	0.18	24	0.4	100	S	3303232	3303276
23.00	16.60	16.0	0.5	0.18	0.2	15.42	0.18	29	0.4	120	S	3303233	3303277
21.00	16.95	16.1	0.5	0.20	0.25	15.22	0.18	31	0.4	128	S	3303264	3303314
25.00	18.65	18.1	0.5	0.20	0.2	17.22	0.18	35	0.4	144	S	3303234	3303278
23.55	17.20	16.1	0.5	0.18	0.2	15.40	0.18	31	0.4	156	R	3303235	3303279
29.55	23.20	22.1											
29.00	22.65	22.1	0.5	0.20	0.2	21.20	0.18	43	0.4	176	S	3303236	3303280
33.00	26.65	26.1	0.5	0.20	0.2	25.22	0.18	53	0.4	216	S	3303324	3303321
37.50	31.15	30.6	0.5	0.18	0.2	30.00	0.18	63	0.4	256	S	3303237	3303281
17.00	10.65	9.1	0.5	0.23	0.25	8.40	0.18	11	0.5	48	S	3303238	3303282
19.00	12.65	12.1	0.5	0.25	0.25	11.20	0.18	15	0.5	64	S	3303267	3303318
21.00	14.65	14.1	0.5	0.25	0.25	13.40	0.18	19	0.5	80	S	3303239	3303283
23.00	16.60	16.0	0.5	0.23	0.25	15.12	0.18	24	0.5	100	S	3303240	3303284
29.00	22.65	22.05	0.5	0.25	0.25	21.20	0.18	29	0.5	120	S	3303241	3303285
29.00	22.65	22.05	0.5	0.25	0.25	21.80	0.18	29	0.5	120	S	3303241	3303286
24.00	17.65	16.1	0.5	0.25	0.25	15.40	0.18	25	0.5	128	R	3303243	3303287
30.00	23.65	21.1											
27.00	20.65	20.1	0.5	0.25	0.25	19.40	0.18	31	0.5	128	S	3303242	3303288
29.00	22.65	22.05	0.5	0.25	0.25	21.20	0.18	35	0.5	144	S	3303244	3303289
33.00	26.65	26.1	0.5	0.23	0.25	25.24	0.18	39	0.5	160	S	3303245	3303290
23.00	26.65	26.1	0.5	0.23	0.25	25.24	0.18	43	0.5	176	S	3303246	3303291
37.00	30.65	30.1	0.5	0.23	0.25	29.40	0.18	51	0.5	208	S	3303247	3303292
37.00	30.65	30.1	0.5	0.23	0.25	30.00	0.18	51	0.5	208	S	3303247	3303293
41.00	34.65	34.1	0.5	0.25	0.25	33.90	0.18	59	0.5	240	S	3303248	3303294
19.70	13.35	12.2	0.5	0.25	0.35	11.2	0.23	11	0.65	48	S	3303325	3303322
19.70	13.35	12.2	0.5	0.25	0.35	11.2	0.23	12	0.65	52	S	3303268	3303319
19.70	13.35	12.2	0.5	0.25	0.35	11.2	0.23	13	0.65	56	S	3303359	3303323
22.10	15.75	14.6	0.8	0.25	0.35	13.95	0.23	15	0.65	64	S	3303249	3303295
24.10	17.75	16.6	0.8	0.25	0.35	15.80	0.23	19	0.65	80	S	3303250	3303296
24.10	17.75	16.6	0.8	0.25	0.35	15.35	0.23	19	0.65	80	S	3303250	3303297
23.75	17.40	16.25	0.5	0.25	0.35	16.57	0.25	19	0.65	100	R	3303251	3303298
30.25	23.90	22.75											
23.75	17.40	16.25	0.5	0.25	0.35	15.35	0.25	19	0.65	100	R	3303251	3303299
30.25	23.90	22.75											
23.75	17.40	16.25	0.5	0.25	0.35	15.91	0.25	19	0.65	100	R	3303251	3303300
30.25	23.90	22.75											
23.75	17.40	16.25	0.5	0.25	0.35	16.77	0.25	19	0.65	100	R	3303251	3303301
30.25	23.90	22.75											
28.10	21.75	20.6	0.8	0.25	0.35	21.00	0.23	24	0.65	100	S	3303252	3303302
29.60	23.25	22.1	0.5	0.25	0.35	21.40	0.23	27	0.65	112	S	3303263	3303313
29.60	23.25	22.1	0.5	0.25	0.35	21.1	0.23	28	0.65	116	S	3303269	3303320
38.70	31.70	30.6	0.8	0.23	0.35	30.30	0.23	35	0.65	144	S	3303253	3303303
38.70	31.70	30.6	0.8	0.23	0.35	30.30	0.23	39	0.65	160	S	3303254	3303304
38.70	31.70	30.6	0.8	0.23	0.35	30.30	0.23	41	0.65	168	S	3303255	3303305
16.70	10.35	9.20	0.5	0.25	0.5	8.40	0.25	7	0.8	32	S	3303265	3303316
19.70	13.35	12.2	0.5	0.5	0.5	11.20	0.25	10	0.8	44	S	3303260	3303311
19.70	13.35	13.3	0.75	0.25	0.5	12.22	0.23	10	0.8	44	S	3303261	3303312
23.70	17.35	17.3	0.75	0.25	0.5	16.20	0.30	15	0.8	64	S	3303256	3303306
23.70	17.35	16.2	0.5	0.25	0.5	15.20	0.25	15	0.8	64	S	3303262	3303307
23.70	17.35	17.3	0.75	0.25	0.5	16.20	0.30	15	0.8	80	R	3303257	3303308
30.10	23.75	23.3											
23.70	17.35	17.3	0.75	0.25	0.5	15.96	0.30	15	0.8	80	R	3303257	3303309
30.10	23.75	23.3											
23.80	17.45	17.2	0.75	0.25	0.6	16.60	0.30	12	1.0	64	R	3303259	3303310
29.80	23.45	23.2											

Please check **Dimension Q** because several versions are available.